

LOC	DIST	REVISIONS			
F	CHR	DESCRIPTION	DATE	OWN	APVD
CM	00	L	REV & REDWN PER EC 0638-0222-99	07-JAN-00	LM KC

- PARTS COMPLY TO AMP SOLDERABILITY SPECIFICATION 109-11-3.
- CIRCUIT IDENTIFICATION CHARACTERS ARE ADJACENT TO THE INDICATED CAVITIES, BUT LOCATION AND ORIENTATION MAY DIFFER FROM PRINT.
- DIMENSIONS IN BRACKETS ARE IN INCHES.

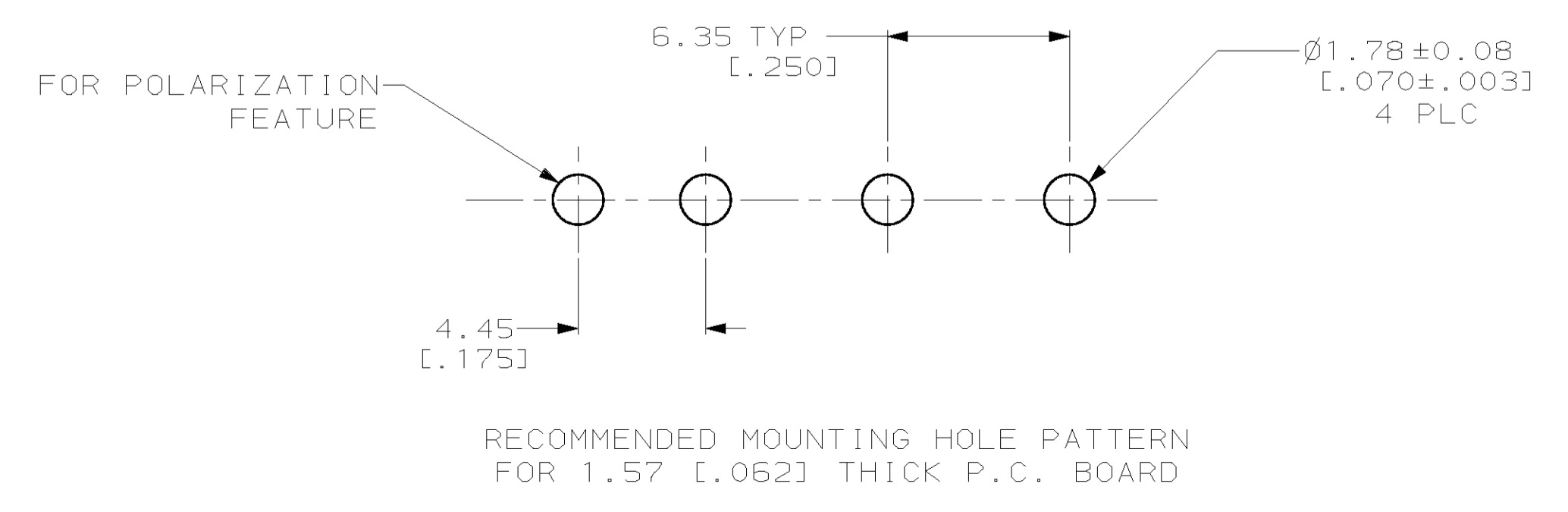

PHOSPHOR BRONZE, PRE-TIN PIN CONTACT MATERIAL AND FINISH	NYLON, UL94V-2, NATURAL HOUSING MATERIAL	641965-1 PART NO
THIS DRAWING IS A CONTROLLED DOCUMENT. DIMENSIONS: mm (INCHES) TOLERANCES UNLESS OTHERWISE SPECIFIED: 0 PLC ± 1 PLC ± 2 PLC ±0.13 [.005] 3 PLC ± 4 PLC ± ANGLES 40°-30° MATERIAL SEE TABLE FINISH SEE TABLE		DWN L. McEACHIN 07-JAN-2000 CHK K. COBLE 07-JUN-2000 APVD K. COBLE 07-JUN-2000 NAME AMP Incorporated Harrisburg, PA 17105-3608 PRODUCT SPEC APPLICATION SPEC SIZE A1 CAGE CODE 00779 DRAWING NO C-641965 WEIGHT CUSTOMER DRAWING SCALE 5:1 SHEET 1 OF 1 REV L

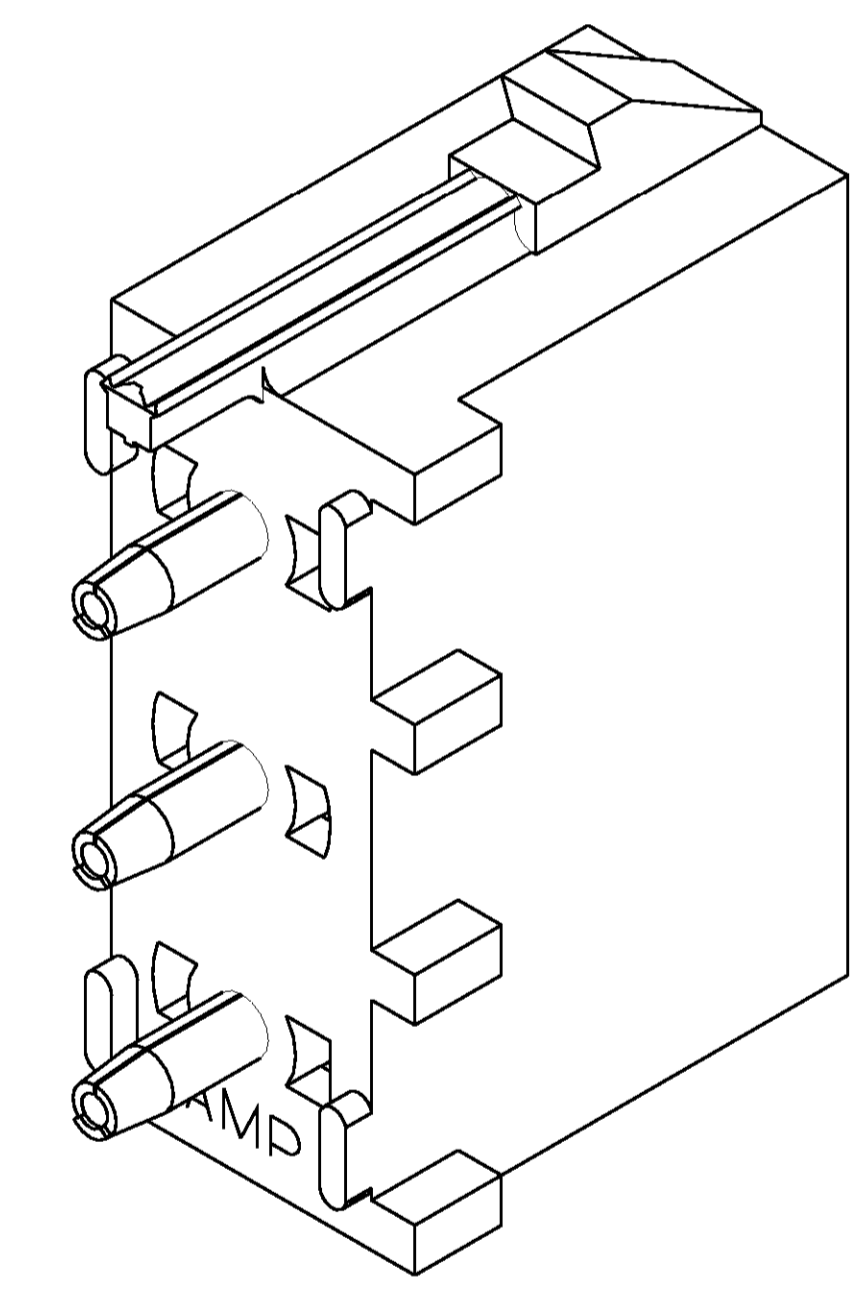
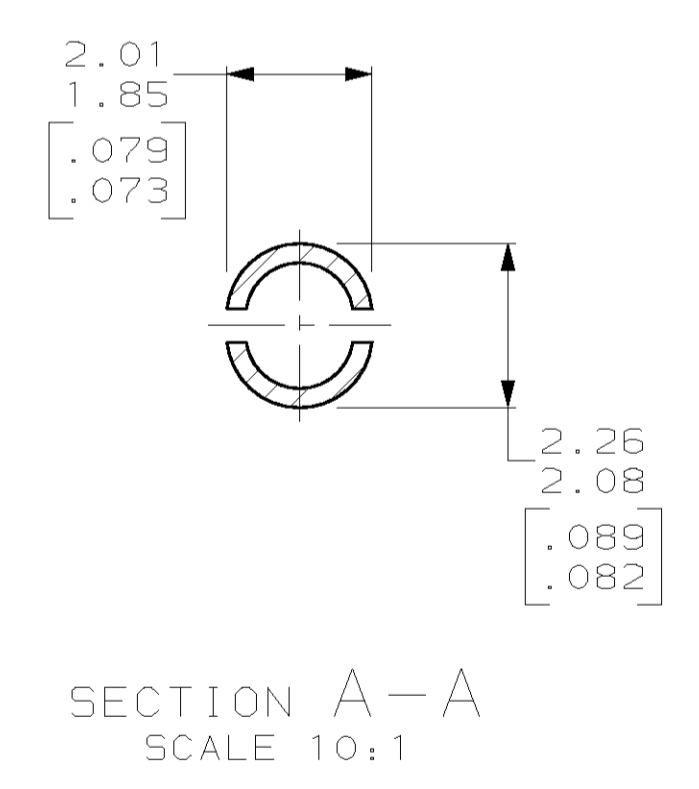
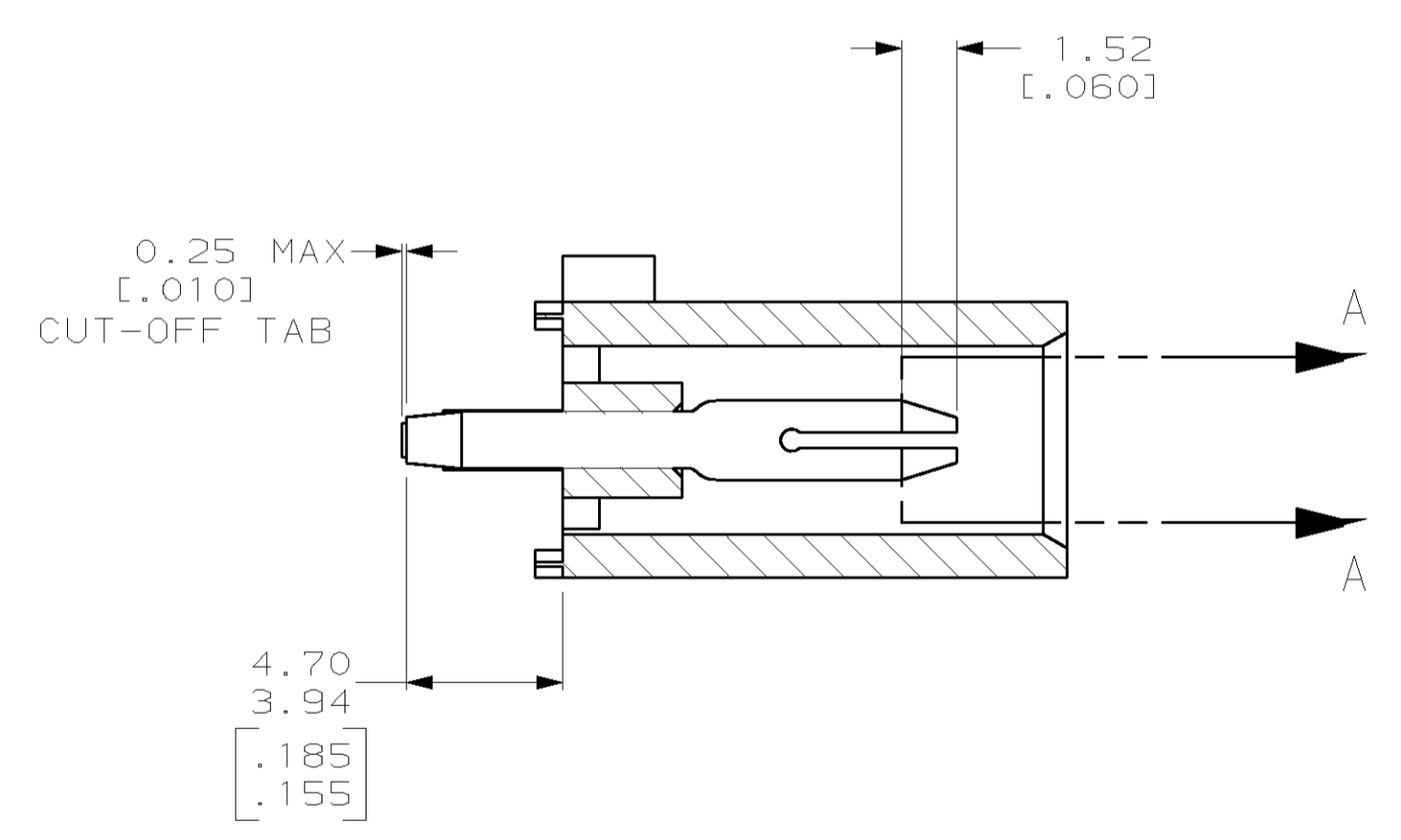
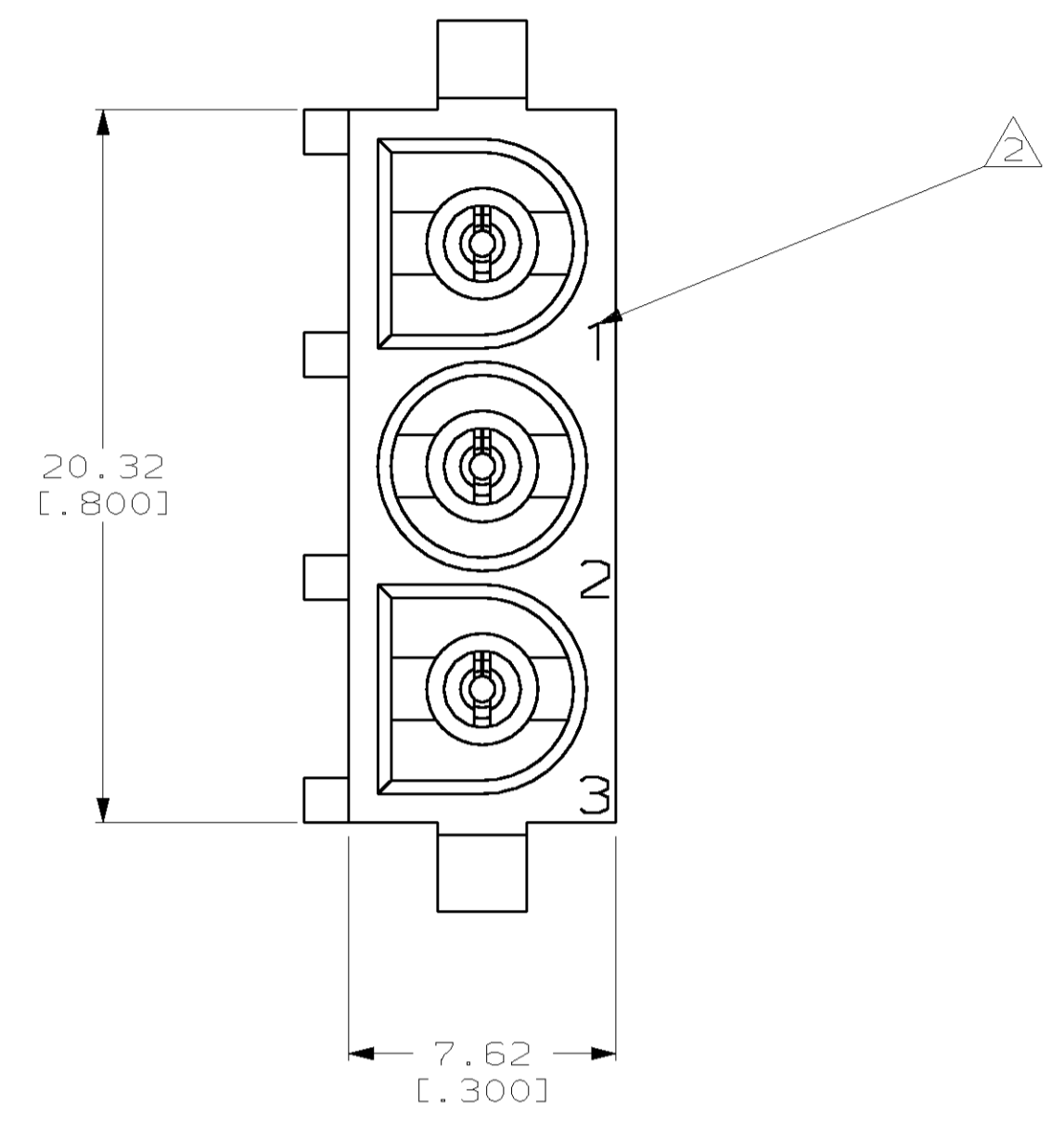
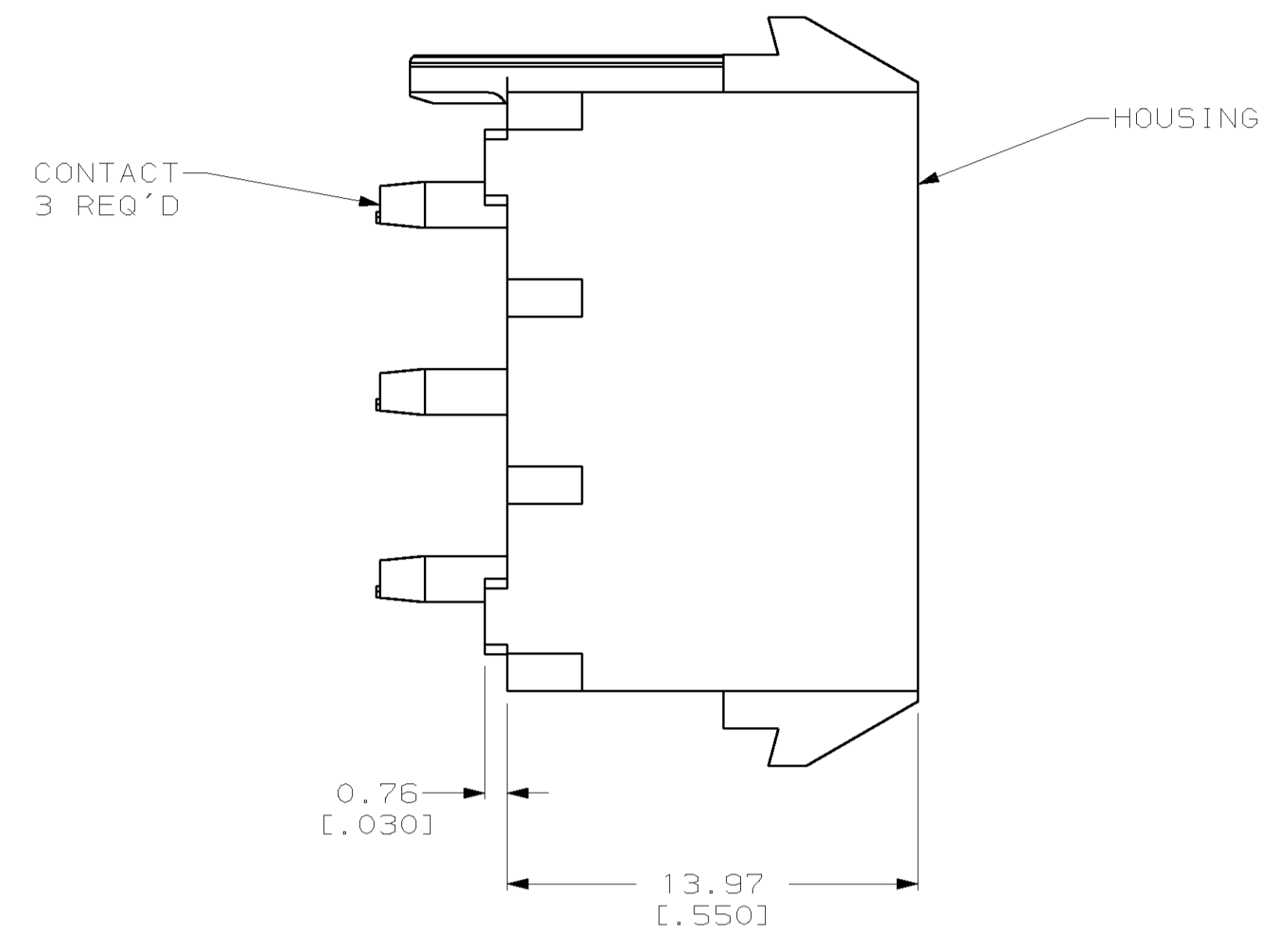
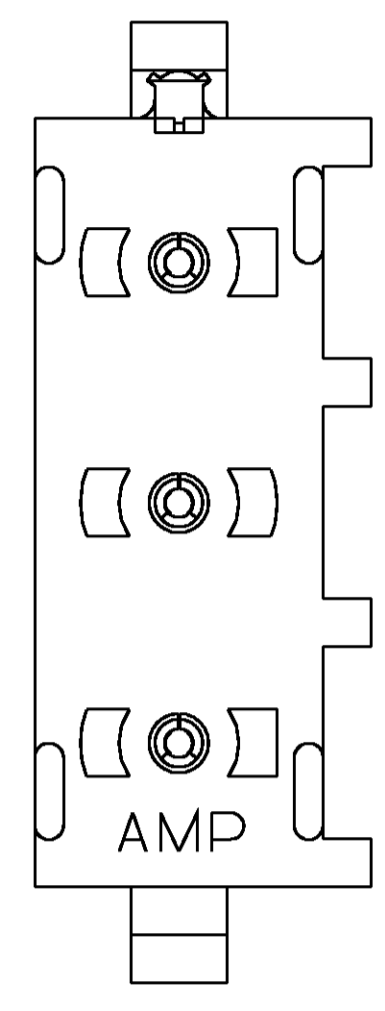